

REV	DESCRIPTION	DATE

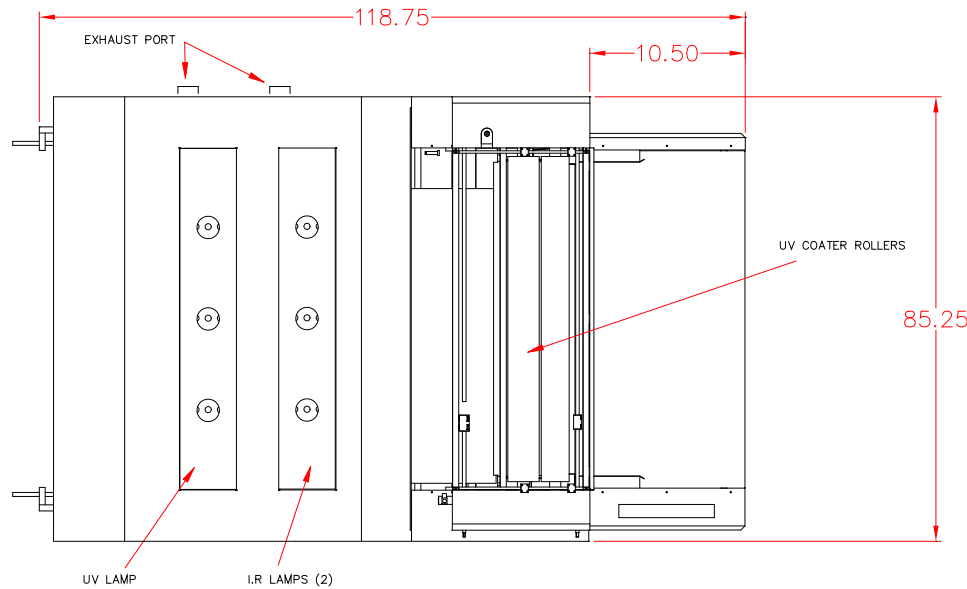

ELECTRICAL REQUIREMENT:  
 INPUT VOLTAGE: 208-220/240VAC 3PH 60HZ  
 RUNNING AMPERAGE: 75A  
 SERVICE DISCONNECT: 100A  
 SHEET SIZE: 63"

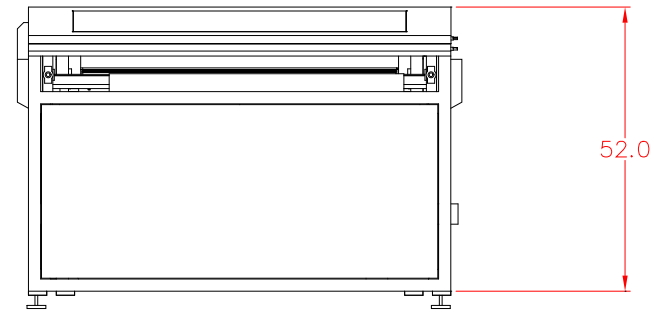
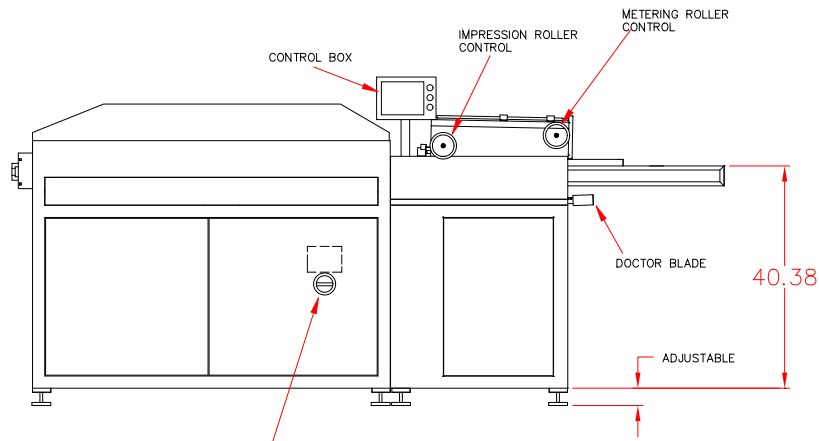

MAIN POWER DISCONNECT SWITCH.  
 POWER INPUT CONNECTION, INSIDE CABINET  
 ABOVE DISCONNECT SWITCH.

**TEC LIGHTING, INC** 905 MARINER ST., BREA, CA 92821  
 PH: 714-529-5068 FAX: 714-529-0344

UNLESS OTHERWISE SPECIFIED TOLERANCE ARE: INCH DECIMAL .XXX ±.010 .XX ±.030 ANGLE ±1/2° FRACTIONAL ±1/32 DO NOT SCALE DRAWING	SYSTEM MODEL NO.:	DESCRIPTION: MEGACOAT 63" MC63 OUTLINE DRAWING
APPROVALS	DATE:	REV. N/C
DRAWN A.BELTRAN	08/16/11	DRAWING NO. MC6063
ENGR. DH	08/16/11	SCALE: 1/16"=1'
APPR. DH	08/16/11	FILE NO. SHEET NO.